

DESIGN OF POWER ELECTRONIC SYSTEM WITH VARIABLE TOPOLOGY OF THE MAIN CIRCUIT FOR EDUCATIONAL SUPPORT OF LABORATORY EXERCISES OF POWER SEMICONDUCTOR CONVERTERS

Michal Frivaldsky

Department of mechatronics and electronics, Faculty of electrical engineering and information technologies, University of Zilina (Slovakia)

Abstract

Power electronics emerges more and more within daily life. Its use is widely increased within many application areas, at the same time, industries are emerging in which this technology is being involved for the first time ever. Regarding this trend, there is need for qualified and experienced people with the knowledge of the power electronic systems. This contribution presents the way how to support educational process of the power electronics, while the focus is given here on the experimental-laboratory training. We have developed a unique power electronic system experimental board, which is equipped with necessary electronic components to be able to form standard and advanced topologies of power semiconductor converters. The students can understand operational principles of power rectifiers, DC/DC switched regulators, isolated DC/DC converters, while open loop and closed loop operation can be studied as well. Final paper will contribute with key construction aspects, main circuit components and circuit topologies with their operational principles and examples from measurements. The paper should inspire more university professionals working in this field, i.e. it supports the idea how to increase the practical way of the university study in the field of electrical engineering.

Keywords: *Power semiconductor device, power semiconductor converter, power electronics, topology, control.*

1. Introduction

A sample of a universal measuring device with a variable topology of the main circuit is a device that serves as an educational aid for students. The student can accept his own designs of non-isolated and isolated topologies of DC/DC converters. With the help of measuring points and measuring bridges, the student has access to the important course of the given topologies. The work was created from the following versions of some functional as well as visual optimization devices. This work serves as a manual for a universal measuring device. It contains a theoretical description of the functions of individual topologies of DC/DC converters and the manual for the device itself, with the help of which the student should be able to implement his design of the given converter into this device and set all the functional blocks of the device according to his design.

2. Design

The device will serve as a teaching aid for students attending teaching courses dedicated to the design of power semiconductor converters. This universal power converter system is intended for the so-called "rapid prototyping learning", where students can test their design of a power semiconductor converter in a short time. Individual power circuits are configured flexibly, i.e. the choice of investigated topology is implemented using plug-in modules, which are designed in such a way that after connecting the selected plug-in module, it completes the missing connections on the main board and thus the preferred topology.

The control board is implemented as a plug-in module and is connected to the main power board using connectors (jumpers). The power board also contains a variable input rectifier that can work in node or bridge connection. The wiring configuration is done by inserting the jumper wire into the terminal block located on the board next to the power terminal block, creating a rectifier bridge connection. The design of the main power board is provided in such a way that the measurement is possible separately on the rectifier or in common connection with the DC/DC converter.

Figure 1. Physical prototype of power electronic system with variable topology of the main circuit.

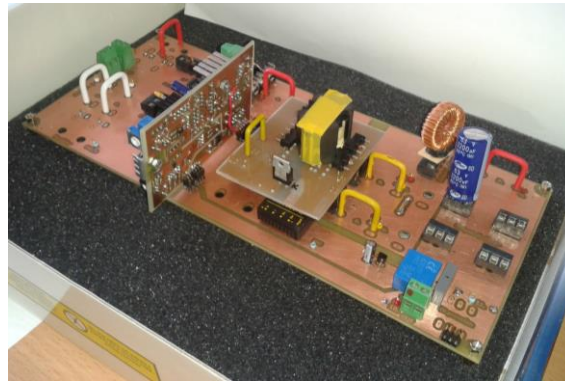

3. Methods

The designed system enables to understand basic and advanced operational principles of the most common power semiconductor circuits, i.e. rectifiers, DC/DC regulators – SMPS (buck, boost, buck/boost), isolated DC/DC converter (flyback and forward) and half and full bridge topologies of DC/DC converters. By the experimental measurements, the students became familiar with physical operation, thus they are able to confirm the theoretical expectations on the given topology operation. Working with such system requires user guide, so here a key functionality is presented. The control board enables to define:

Table 1. Functionality description of control card

Setting components/functionality	
1.	R_T – switching frequency (f_{sw})
2.	Setting the deadtime value (t_d)
3.	Setting the duty cycle (D)
4.	Setting the value of overcurrent protection (0 – 12 A)
5.	Output voltage value for feedback loop regulation
6.	Switching frequency range
7.	Feedback loop enable
8.	Selection for fixed or variable value of duty cycle (D)
9.	Setting of maximum duty cycle (50% or 100%)
10.	Control system (external/internal)
11.	Selection of the output voltage
Connectors	
A.	Power supply for control board (15V)
B.	Connector for capacitor of the PI regulator of feedback loop
C.	Connector for resistor of the PI regulator of feedback loop
D.	Connector for external control DSP or μC
E.	Connectors for control board and power board

Figure 2. Control board layout indicating key component for functionality setting.

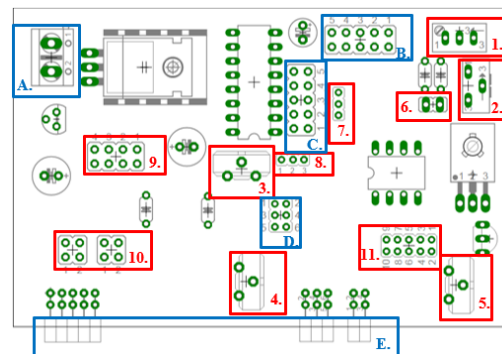

The control board is designed as a plug-in module, which is connected to the main power board using connectors. The control board contains the circuits necessary to control the switching elements on the power board, it also contains evaluation circuits of the protections that are implemented in the device. Figure 2 shows the layout of the components of the control board, with the adjustment elements (red) and terminal blocks (blue) marked. The table 1 briefly describes the meaning of individual setting elements and connectors. By using this simple jumper positioning, the student can flexibly modify circuit topology and control functionality as well.

The main power board contains all the necessary parts to revive the designed power converter. It contains the circuits of the input rectifier, the main circuit of the DC/DC converter (after the implementation of the relevant plug-in module determining the converter topology), various types of protections. The main board has measurement points and measurement bridges for easier work when measuring electrical variables important for specifically selected topologies of the DC/DC converter or input rectifier. Figure 3 shows the distribution of the components of the main board with marked connection terminals and elements of the initial setting of the board before experimenting. The explanation of individual elements is in the table 2.

Figure 3. Power board layout indicating key component for functionality setting.

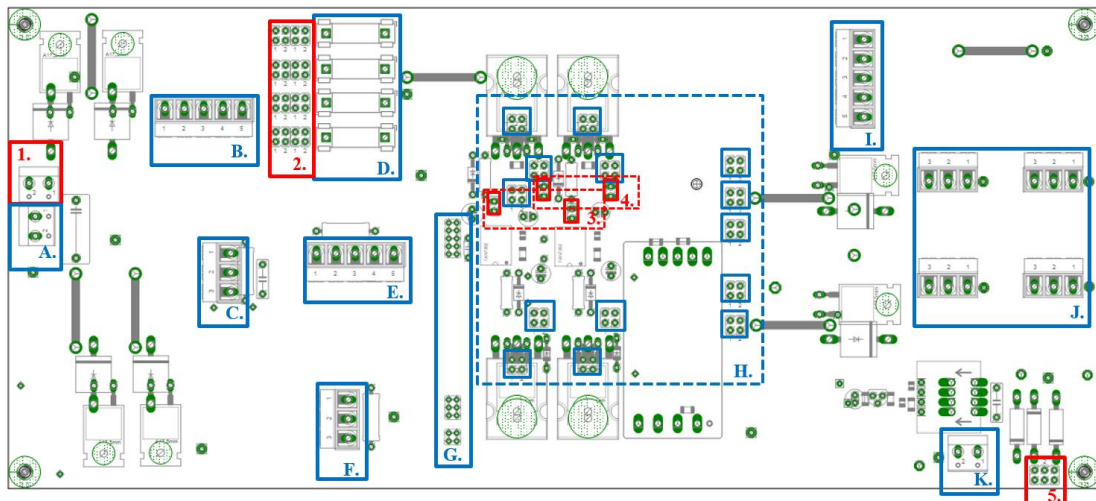

Table 2.

Setting components/functionality	
1.	Topology selection of rectifier
2.	Connectors for fuse selection
3.	Connectors between drivers and power transistors
4.	Connectors between drivers and transistor emitters
5.	Connector for selection of overvoltage protection value
Connectors	
A.	Connector for power supply of rectifier
B.	Connector for inductive rectifier filter
C.	Connector for capacitive rectifier filter
D.	Fuse field
E.	Connector for boost converter inductor and/or capacitive divider of half-bridge converter
F.	Connector for capacitive divider of half-bridge converter
G.	Connector for control board connection
H.	Connector for slot modules determining topology
I.	Connector output inductive filter connection
J.	Connector for output capacity connection
K.	Connector for load connection

4. Conclusion

Power electronic systems are becoming essential part of any advanced electronic system regarding industrial, energy or customer segment. It is therefore very important that electrical engineering studies, provides flexible tool to find innovative education process, focused on the experimental findings of the basic principles of power electronic converters. This paper provides description of universal measuring system, which enables to became familiar with operational principles of standard power converter topologies.

References

- Hockicko P, Tarjanyiova G (2020) *Lab-Based learning in university for primary school students focused on acoustics*. AKUSTIKA: STUDIO D-AKUSTIKA SRO.
- Pavlašek P, Hargas L, Prandova A (2019) *Effective flexible education concept: virtual education environment support of students creativity, flexibility, activity*. EDULEAR 19 International conference.
- Tarjanyiova G, Hockicko P, Kopylova N, Dyagilev A, Ivanikov A (2020) *Comparison of Physics study results at the technical universities in different countries*. ELEKTRO 2020 International conference.
- www.ti.com 2008 Power Supply Topologies.